



TECHNICAL BULLETIN

Audco

Steel Taper Plug Valve

FCD AUEETB0003-01 06/13



Range and Index

Regular Pattern, Standard Type



Short Pattern, Standard Type



Venturi Pattern, Standard Type



Jacketed



API MONOGRAM
 Valves shown in this catalogue
 are manufactured under the terms of our
 Licence to use the API Monogram which
 covers flanged straightway valves.

mm Inches	15 ½	20 ¾	25 1	40 1½	50 2	80 3	100 4	150 6	200 8	250 10	300 12	Page No.
ANSI 150												10
ANSI 150												11
ANSI 300												12
ANSI 150												13,14,15
ANSI 300												

Old Fig. No	New Fig. No	Page	Old Fig. No	New Fig. No	Page	Old Fig. No	New Fig. No	Page
MS22	MRW222CC	10	MW32	MSG322CC	12	LJ23	MFW233CC	13
MS23	MRW233CC	10	MW33	MSW333CC	12	LJS23	MFG233CC	13
MS24	MRW244CC	10	MW34	MSW344CC	12		MZW233CC	14
LS23	MSW233CC	11	MW39	MSW399CC	12		MZG233CC	15
LGS23	MSG233CC	11	MWJ33	MFW333CC	13			

Principles and Maintenance

Principles of Operation

The Audco Taper Plug Valve, manufactured in sizes from ½” to 12”, is used on a wide variety of liquid, gaseous and slurry services.

The tapered plug is held firmly into its tapered seat but can be so adjusted that complete leaktightness is achieved together with smooth valve operation. The tapered seating surfaces of the plug and body are not exposed to the line fluid when the valve is in the open position, so that the effects of corrosion and erosion are confined to the less important parts of the valve. Also since there is a straight flowpath through the valve, there is very little resistance to flow and pressure loss is minimised.

Super LoMu Treatment

All Carbon Steel taper plug valves, sizes 1½” and above, have plugs with Audco Super LoMu treatment. In this unique process, low friction PTFE is incorporated in the surface structure of the valve plug metal. This gives easier operation and enhanced resistance to taper lock over thousands of operations or many years of service.

Sealant Type

All valves described in this catalogue are normally filled with 733 sealant.

If you require a different sealant, please state this at the ordering stage so that the valve can be assembled with the correct sealant.

In those cases where no previous experience exists regarding the suitability of the normal sealant for the line fluid on which the valve is to be used, please provide full service details so that we may ensure that the correct type of sealant is used in the assembly of the valve.

Maintenance

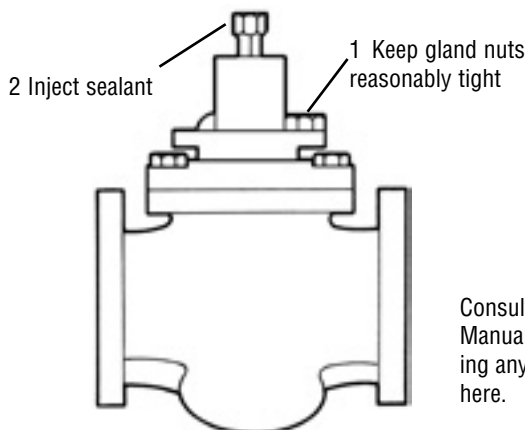

Consult Audcofull Installation, Operation and Maintenance Manual, available on request, before attempting any maintenance operations other than those described here.

Sealant Injection

Lubrication of the seating surfaces is by means of a specially compounded valve sealant which is fed into the operating shank of the valve, either in the form of sealant sticks or by a sealant gun. The sealant then passes through a non-return valve into a system of grooves and ducts on the plug and body.

As the valve is operated, a film of sealant is spread evenly between the seating surfaces and, if a valve should become difficult to turn, sealant pressure may be built up in the small end chamber underneath the plug, so that the plug is eased slightly in its seat and operability is restored.

The design of the sealant system ensures that any sealant groove which is exposed to the line fluid during operation, is isolated from the sealant supply. Thus loss of sealant into the pipeline is avoided.

As well as facilitating valve operation, the special sealant also perfects the seal between the accurately matched seating surfaces and so assures positive leaktightness.

Audco sealants are specially formulated for use in Audco valves. It is extremely important that only Audco sealant be used as they retain their properties over a wide temperature range, resist corrosive attack and have many other characteristics necessary for the efficient operation of Audco valves. Similarly, Audco sealant should not be used for any purpose other than injecting into Audco taper plug valves in the way described in our operating instructions, except with our express recommendation.

Frequency of Valve Operation	On average valve should be lubricated	
	Not more than	Not less than
Over 100 times per shift	Each shift	Weekly
10 to 100 times per day	Daily	Weekly
1 to 10 times daily	Weekly	Monthly
1 to 30 times monthly	Monthly	Quarterly
Less frequently	Quarterly	Twice Annually

Sealants (methods of injection)

Audco sealants are formulated specially for use in Audco valves and no other types of sealant should be used, nor should Audco valve sealants be used for any purpose other than injecting into valves without our express recommendation.

Injection by Sealant Gun

All valves are fitted with a taper threaded sealant injector positioned in the centre of the stem or as a side feed in the body.

Sealant Guns

Sealant guns are fitted with flexible hoses giving a hook-on connection to the combination sealant injector on the valve.

400-D Sealant Gun

Hand operated hydraulic gun, fitted with a pressure gauge. Suitable for small number of valves or valves in remote locations, this gun is designed to take Size 'K' sealant sticks.

Effortless to operate, the 400D gives positive indication of when a valve has been fully charged.

The 400D replaces the now obsolete ALG4 gun. Cartridges for use with ALG4 gun are still available

10-90 Pneumatic Pump

Trolley mounted, pneumatically operated large capacity injector pump. Suitable for large numbers or sizes of valves, the pump is designed to take five Quarter sealant cans. The pump will run when connected to an air supply that could be a compressed air system or an air bottle.



Sealants (multi-purpose and specialised)

Multi-Purpose Sealants

In recent years the Audco Valves research laboratories have paid great attention to the development of multi-purpose sealants to simplify plant maintenance where many services are encountered. As a result of this research, we are able to offer two sealants which, between them, cover a very wide variety of services and have replaced many of the older Audco sealants. A single multi-purpose sealant can often be used throughout an entire plant, even though that plant handles a variety of fluids. This simplifies maintenance and reduces the number of sealants which need to be stocked.

Lubricating and Sealing Properties

In addition to being suitable for a wide range of services, these sealants have excellent lubricating properties and great film strength. They supplement Super LoMu treatment to reduce friction between the seating surfaces and provide a very effective seal at higher line pressures.

Temperature Range

The temperature range of each sealant is given in these tables but the sealant performance within the given temperature range may vary with the particular fluid being handled.

Multi-Purpose Sealants

Sealant	Form	Colour	Temp Range °C (°F)		Recommended for	Do not use on
			Min	Max		
733	K Sticks Cartridges Bulk	Cream	-20 (-5)	250 (480)	Most Hydrocarbon services, Butane, propane, gasoline, kerosene, oils, fuel oils, most hydrocarbon solvents. Sweet and sour natural and manufactured gas with water organic condensates, LPG systems, glycols	Strong alkali and high aromatic and chlorinated solvents
735	K Sticks Hard grade Bulk only	Black	-40 (-40)	325 (620)	Premium Multipurpose Sealant suitable for a range of fluids including hydrocarbon, water, amines and methanol Suitable for high / low temperature applications	Neat petroleum products Strong mineral acids Chlorinated and aromatic acids
731	K Sticks Cartridges Bulk	Cream	-15 (0) -20 (-5) -25 (-13)	230 (450) 230 (450) 230 (450)	Most chemical plant services, compressed air, water, aqueous solutions, dilute acids, all alkaline solutions tars and bitumens	Strong acid solutions, hydrocarbons, chlorinated and aromatic solvents

Sealants (multi-purpose and specialised)

Specialised Sealants

Sealant	Form	Colour	Temp Range °C (°F)		Recommended for	Do not use on
			Min	Max		
985	K Sticks Cartridges Soft grade Bulk only	Light Brown	-10 (12)	150 (300)	Sweet and sour natural and manufactured gas with water/organic condensates Preferred at elevated temperatures	As 733
201	K Sticks Cartridges Bulk	White	-7 (-20)	200 (390)	Domestic water services, foodstuffs and pharmaceuticals	As 731
147	K Sticks Cartridges Bulk	White	-10 (14)	70 (160)	Nitrating acids, sulphuric acid and other oxidising elements	Hydrocarbon chlorinated and aromatic solvents
563	K Sticks Cartridges Bulk	Yellow	-10 (14)	150 (300)	Chlorinated and aromatic hydrocarbon solvents	Strong acids, nitrating acids, water and water based services and alcohols
734	K Sticks Cartridges Bulk	Cream	0 (32)	170 (340)	Water, high pressure, hot water and steam	As 731
591	K Sticks Cartridges Bulk	Cream	0 (32)	300 (570)	Petroleum based heat transfer oils. Hot fuel oil to 120°C	As 733
608	K Sticks Cartridges Bulk	Off White	0 (32)	340 (650)	Hot hydrocarbon gases and vapours including high temperature cracking and reforming Strong acids and alkalis to 150°C	Aromatic and chlorinated solvents Liquid hydrocarbons and nitrating acids
733LT	K Sticks Cartridges Bulk	Brown	-30 (-20) -46 (-50)	150 (300) 100 (200)	As for 733, but particularly useful at lower temperatures and winter conditions	As for 733
574	Cartridges Soft grade Bulk only	Beige	-50 (-58)	50 (120)	Ammonia and brine	As 731
2977	K Sticks Cartridges Soft grade Bulk only	Black	-40 (-40)	325 (620)	As for 735, also oil and water mixtures where water content is above 50% in the mixture	As 735

Storage and Handling of Sealants

Sealants should be stored in clean, dry conditions away from heat and flame and strong oxidising agents. Keep containers closed and store sealants in their original containers until required for use.

All of our sealants have flash points above 150°C but some will burn if subjected to sufficiently fierce flames. If any sealant is incinerated avoid breathing the fumes.

Normal hygiene procedures should be followed e.g. avoid prolonged skin contact, wash hands thoroughly after use, etc.

Specific data sheets for each sealant are available on request.

Standard Construction

Audco Standard Type Valve

The Audco Standard type valve has its integral operating shank at the large end of the taper plug. The plug is seated by means of forces applied through the gland packing housed in the cover which also seals the shank against leakage.

To prevent damage to the packing where it would otherwise rub on the top of the plug, it bears on a metal shim which is clamped between the body and the cover. This reduces friction between the plug and the packing and also acts as a separate and very effective seal against leakage of the line fluid into the packing space.

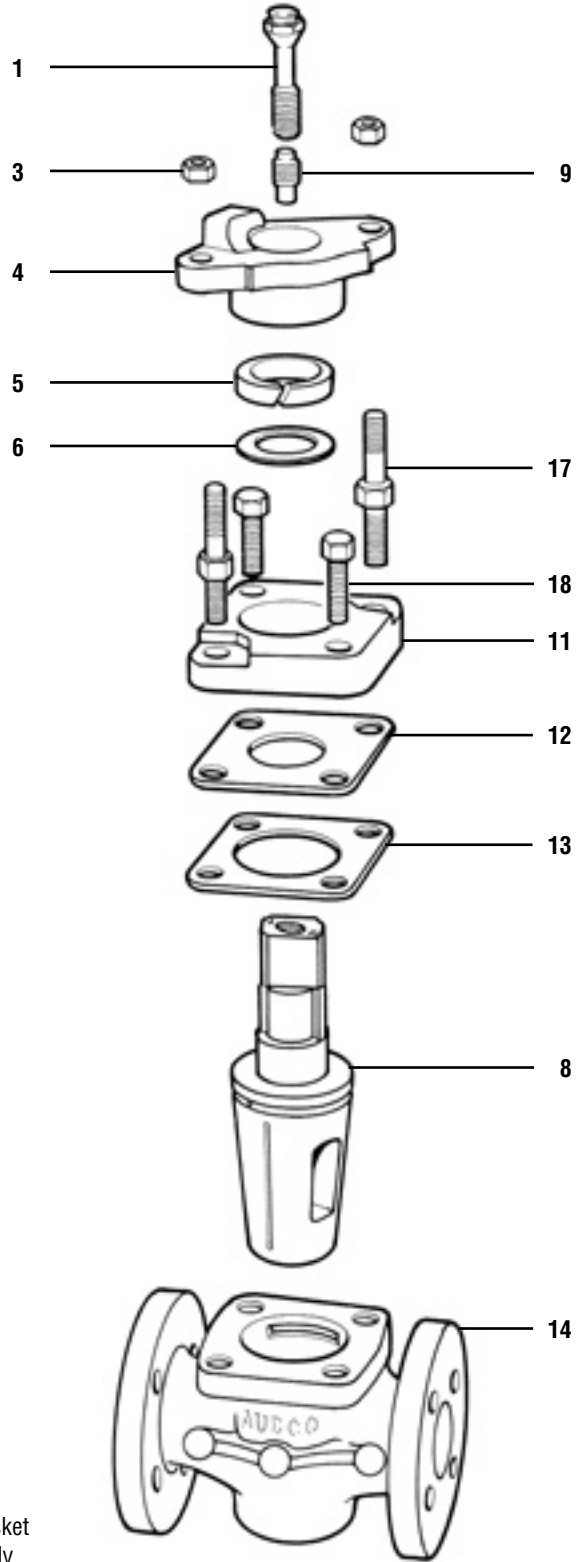
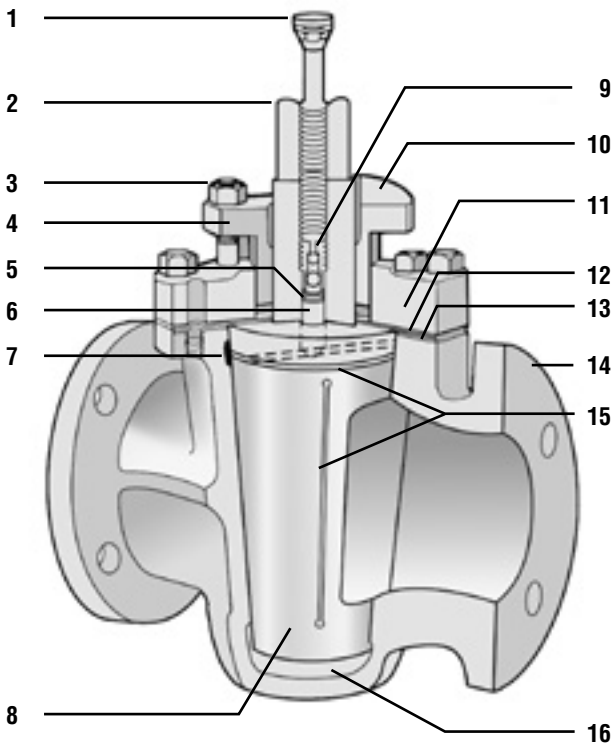

- | | | |
|----------------------|----------------|--------------------|
| 1 Sealant Injector * | 7 Sealant Duct | 13 Gasket |
| 2 Indicator | 8 Plug | 14 Body |
| 3 Gland Nuts | 9 Check Valve | 15 Sealant Grooves |
| 4 Gland | 10 Stop | 16 Sealant Chamber |
| 5 Gland Packing | 11 Cover | 17 Gland Studs |
| 6 Packing Ring | 12 Shim | 18 Cover Bolts |

* Sealant Screw (up to 40mm)

Materials and Figure Numbers

Body Materials

	SAV Specification	Used for	Comparable Specifications	Form
CARBON STEEL	ASTM A216 Gr.WCB but with max. C 0.25%	Flanged valves all sizes. Screwed & socket weld end size 40-80mm	BS EN 10213 GP240GH	CASTING
	ASTM A105	Screwed & socket weld end valves sizes 15-25mm	BS 1503-164-490	FORGING

Alternative materials available on request, including Transco BG, GBE/C9 Specification.

Plug Materials

	SAV Specification	Used for	Comparable Specifications	Form
CARBON STEEL	ASTM A216 Gr.WCB but with max. C 0.25%	Sizes 100mm and larger	BS EN 10213-2 GP240GH	CASTING
	ASTM A105	Sizes 15-25mm		FORGING
	BS 970 080M15	Sizes 15-25mm	ASTM A29 GR.1016	BAR
GREY IRON	ASTM A278 No.30 / No.40	Class 150 only, sizes 50mm and larger	BS EN 1561 EN-JL1030 / EN-JL1040	CASTING

Figure Numbering

A familiarity with our figure number system is not necessary when specifying or ordering our valves. Providing a full description of the valve is given, our Sales Office will translate this into a figure number. A full description of the valve would begin with "Audco Standard Type Steel Valve", and would then go on to give size, pressure rating, flanging details etc.

We give an example below in order to illustrate figure number, but if a fuller explanation is required please request Standards Sheet 300033/Sect 1Q.

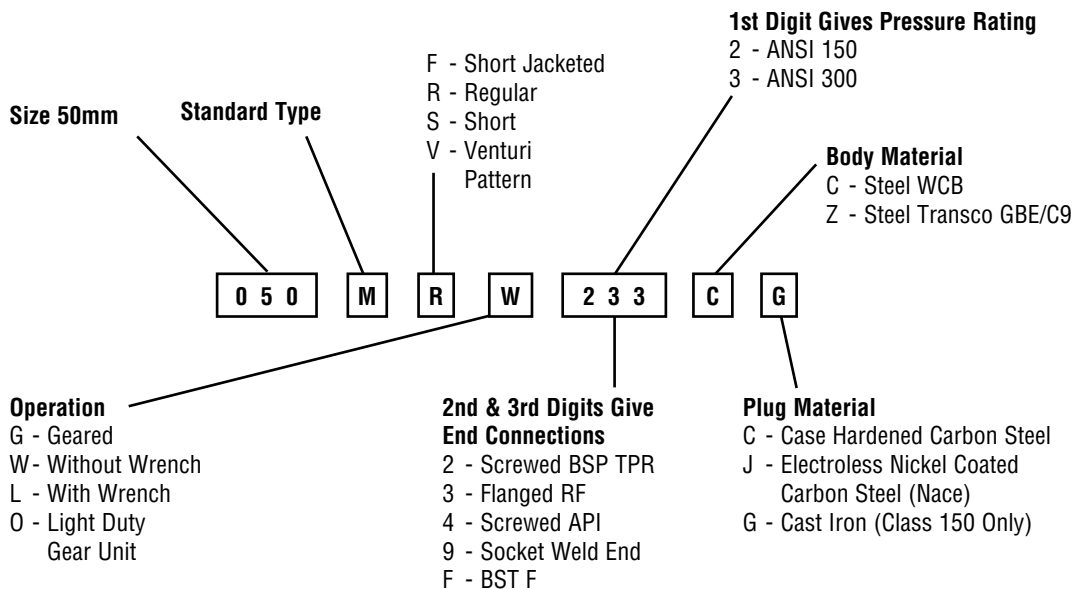

Standards

Steel valves meet the requirements API 6D, API 599, BS 5353 and ANSI B16.34 as standard. Typical standards that we are often asked to comply with are listed in the below table, other standards can be considered against specific request.

BS EN 558-1:1996	Industrial valves. Face-to-face and centre-to-face dimensions of metal valves for use in flanged pipe systems, PN designated valves
BS EN 1226-1:2003	Industrial valves. Testing of valves, Pressure tests, test procedures and acceptance criteria.
BS 5158:1989	Specification for cast iron plug valves.
BS 5353:1989	Specification for steel plug valves.
ASME B16.10	Face-to-face and end-to-end dimensions of ferrous valves.
ASME B16.34	Valves - flanged and butt welding end.
API 6D / ISO14313	Specification for pipeline valves.
API 599	Steel plug valves flanged or butt welding ends.
NACE MR0175	Sulphide stress cracking resistant metallic material for oil field equipment.
97/23/EC	Pressure equipment directive.

Patterns

Audco steel standard type valves are available in Regular, Short or Venturi Pattern. These terms are defined in BS 5353, API 6D/ ISO 14313 and API 599. The different patterns vary as regards end-to-end dimension and port area for a given size of valve. Regular Pattern valves have the largest port area. Short Pattern valves have a reduced port area as a consequence of their compact face-to-face dimensions which are identical to those for wedge gate valves. Venturi Pattern valves have a reduced port area and a flow path approximating a venturi shape to aid pressure recovery. Face-to-face and end-to-end dimensions conform to ASME B16.10, API 6D / ISO14313 and BS EN 558.

Test Pressures

Valve Rating or Flanging	Maximum C.W.P.		Body Test (Minimum)		Seat Test (Minimum)	
	bar	lbf/in ²	bar	lbf/in ²	bar	lbf/in ²
Class 150 PN 20	19.5	285	29.3	427.5	21.5	313.5
Class 300 PN 50	51.1	740	76.7	1110	56.3	814

There may not be exact equivalence between pressure in bar and in lbf/in² due to rounding (1 bar = 10⁵ Pa).

Test Duration

Each relevant standard defines the minimum length of time for which each test pressure is to be maintained and also the testing operations sequence.

These durations will be adhered to unless a different specification is required against a particular order. If, once fitted into the line, a valve is to be subjected to a greater test pressure or a longer duration of test, then this should be specified and this can be covered at the inspection stage of the finished valve before painting.

Class 150 Regular Pattern

Standard Type

MRW222CC	Screwed BSP Tpr	15-80mm
MRW244CC	Screwed API	15-80mm
MRW233CC	Flanged Class 150 RF	15-150mm

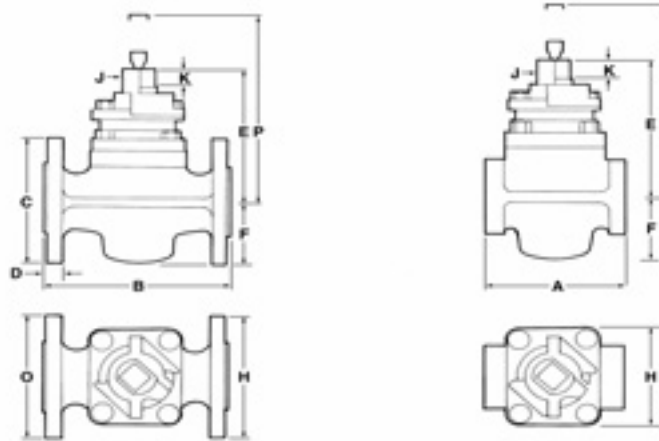

			15	20	25	40	50	80	100
A	End-to-end screwed	mm	95	95	111	133	165	203	-
B	Face-to-face flanged	mm	130	130	140	165	203	241	305
C	Flange diameter ANSI RF	mm	89	98.4	108	127	152	191	229
D	Total flange thickness ANSI RF	mm	9.53	12.7	11.1	17.5	19.1	22.2	25.4
E	CL to top of stem	mm	100	100	114	152	176	229	245
F	CL to bottom of body	mm	48	48	49	70	81	114	140
H	Maximum width of body	mm	71	71	78	105	125	149	219
J	Size of plug square	mm	19.1	19.1	22.2	27.0	31.8	44.3	47.6
K	Depth of plug square	mm	19.8	19.8	21.4	28.6	27.0	44.5	46.0
O	Raised face diameter ANSI RF	mm	34.9	42.9	50.8	73.0	92.1	127	157
P	Clearance to remove screw or lubricator	mm	157	157	171	210	265	327	343
U	CL to end of fitted wrench	mm	152	152	229	318	381	559	711
	Weight (approx) screwed	kg	3.2	3.2	5.0	8.1	13	27	-
	Weight (approx) flanged	kg	3.6	3.6	6.3	10	19	32	54
	Wrench number		2	2	3H	4H	5H	7H	8H
	Sealant stick size		A	A	A	B	C	D	D

Valves are normally supplied with drilled Class 150 flanged having serrated finish raised faces in accordance with ANSI B16.5. Most valves on this page can be supplied with flange drillings to BS EN 1092-1 PN 16 or DIN PN 16.

Class 150 Short Pattern

Standard Type

MSW233CC Flanged Class 150 RF 50-200mm
MSG233CC Flanged Class 150 RF 200-300mm

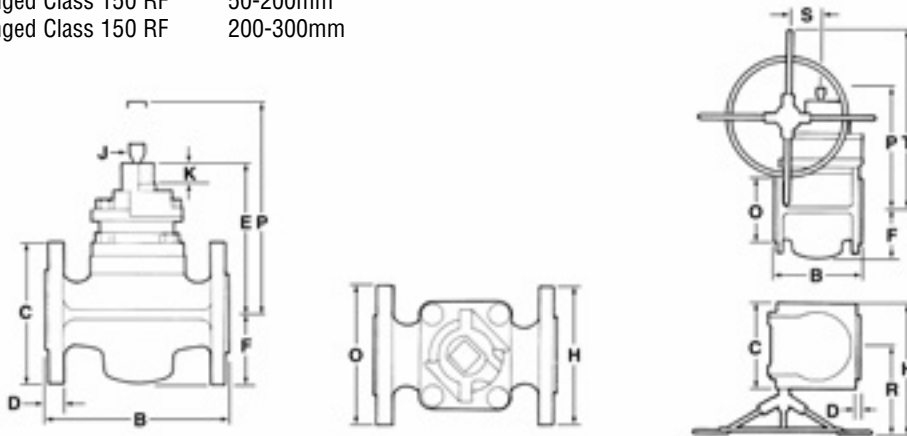

Flanged valves have face-to-face dimensions conforming to BS 5158 PN 10/16 & BS 2080 Class 150 Short, ANSI B16.10 & API 6D Class 150 Short. These valves are thus interchangeable with equivalent gate valves. Flanged valves have patterns conforming to BS 5353, BS 5158, ANSI B16.34, API 6D & API 599 Short (with steel plug).

		50	80	100	150	200	250	300	
B	Face-to-face	mm	178	203	229	267	292	330	356
C	Flange diameter ANSI RF	mm	152	191	229	279	343	406	483
D	Total flange thickness ANSI RF	mm	15.9	19.1	23.8	25.4	30.2	30.2	31.8
E	CL to top of stem	mm	152	208	230	293	327	364	-
F	CL to bottom of body	mm	71.0	102	114	160	179	219	289
G	Handwheel diameter	mm	-	-	-	-	578	578	578
H	Maximum width MSW & MSO	mm	105	144	149	279	343	381	-
H	Maximum width MSG	mm	-	-	-	-	479	516	544
J	Size of plug square	mm	27.0	38.1	41.3	50.8	50.8	50.8	-
K	Depth of plug square	mm	28.6	30.2	44.5	54.0	54.0	54.0	-
O	Raised face diameter ANSI RF	mm	92.1	127	157	216	270	324	381
P	Clearance to remove screw or lubricator MSW & MSO	mm	225	297	324	414	449	483	-
P	Clearance to remove screw or lubricator MSG	mm	-	-	-	-	486	536	597
R	CL to face of handwheel	mm	-	-	-	-	310	310	310
S	CL valve to CL input shaft	mm	-	-	-	-	105	105	105
T	CL to top of handwheel	mm	-	-	-	-	613	676	718
U	CL to end of fitted wrench	mm	318	457	559	1020	1020	-	-
	Weight (approx) MSW & MSO	kg	13	25	36	86	118	181	-
	Weight (approx) MSG	kg	-	-	-	-	150	200	277
	Wrench number		4H	6H	7H	10H	10H	-	-
	Sealant stick size		B	C	D	E	E	E	E
	Number of tapped holes in each flange		0	0	0	2	4	4	8

Valves are normally supplied with drilled Class 150 flanges having serrated finish raised faces in accordance with ASME B16.5. Most valves on this page can be supplied with flange drillings to BS EN1092-1 PN16.

Valves in sizes 150mm and larger have flanges which are not machined on the edges and have some holes threaded. Threads are UNC on ANSI, BS 1560 and BS10 flanges but metric coarse on DIN and BS 4504 flanges. The threaded holes require studs of the same diameter as the bolts they replace.

Class 300 Short Pattern

Standard Type

MSW322CC	Screwed BSP Tpr	15-80mm
MSW344CC	Screwed API	15-80mm
MSW333CC	Flanged Class 300 RF	15-100mm
MSW399CC	Socket Weld end	15-50mm

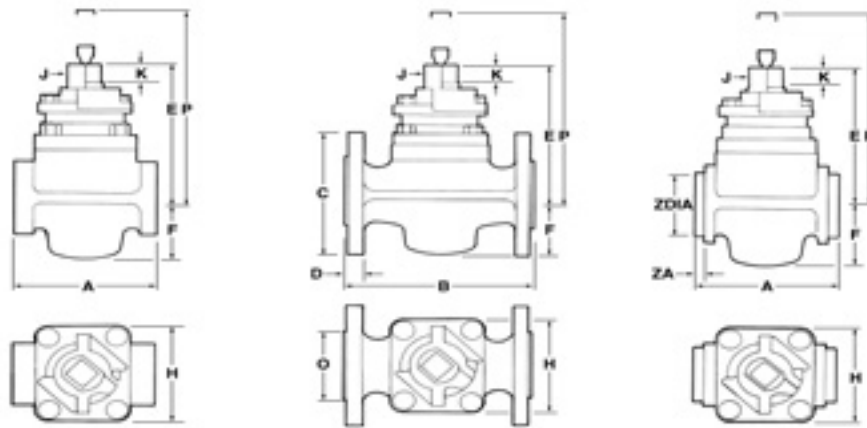

Flanged valves have face-to-face dimensions conforming to BS 5158 PN 10/16 & BS 2080 Class 150 Short, ANSI B16.10 & API 6D Class 150 Short. These valves are thus interchangeable with equivalent gate valves. Flanged valves have patterns conforming to BS 5353, BS 5158, ANSI B16.34, API 6D & API 599 Short (with steel plug).

			15	20	25	40	50	80	100
A	End-to-end screwed & SWE	mm	95	95	111	133	165	203	-
B	Face-to-face	mm	140	140	159	191	216	283	305
C	Flange diameter ANSI RF	mm	95.3	117	124	156	165	210	254
D	Total flange thickness ANSI RF	mm	14.3	15.9	17.5	20.6	22.2	28.6	31.8
E	CL to top of stem	mm	100	100	114	114	176	229	245
F	CL to bottom of body	mm	37	37	49	65	81	114	140
H	Maximum width of body screwed & SWE	mm	71	71	78	104	125	149	-
H	Maximum width of body flanged	mm	78	78	78	105	125	149	149
J	Size of plug square	mm	19.1	19.1	22.2	27.0	31.8	41.3	47.6
K	Depth of plug square	mm	19.8	19.8	21.4	28.6	27.0	44.5	46.0
O	Raised face diameter ANSI RF	mm	34.9	42.9	50.8	73.0	92.1	127	157
P	Clearance to remove screw or lubricator	mm	157	157	171	210	265	325	343
U	CL to end of fitted wrench	mm	152	152	229	318	381	559	711
Z	I.D. of socket SWE (-0.0 +0.25mm)	mm	21.72	27.05	33.78	48.64	61.11	-	-
ZA	Depth of socket SWE	mm	9.53	12.7	12.7	12.7	15.9	-	-
	Weight (approx) screwed & SWE	kg	3.2	3.2	4.5	8.2	13	27	-
	Weight (approx) flanged	kg	3.6	3.6	6.3	14	18	38	75
	Wrench number		2	2	3H	4H	5H	7H	8H
	Sealant stick size		A	A	A	B	C	D	D

Valves are normally supplied with drilled Class 150 flanges having serrated finish raised faces in accordance with ANSI B16.5. Most valves on this page can be supplied with flanges drilled to BS EN1092-1 PN25/PN40.

Class 150 Jacketed Short Pattern

Standard Type

MFW233CC Flanged Class 150 RF 50-150mm

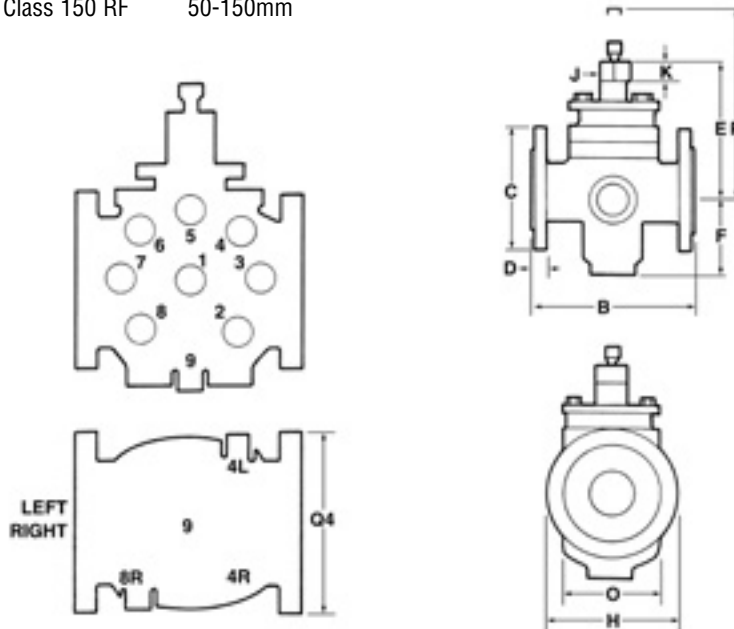

Valves have face-to-face dimensions conforming to BS 5158 PN 10/16, BS 2080 Class 150 Short, ANSI B16.10 & API 6D Class 150 Short. These valves are thus interchangeable with equivalent gate valves. Valves have Patterns conforming to BS 5353, BS 5158, API 6D & API 599 Short (with steel plug).

			50	80	100	150
B	Face-to-face flanged RF	mm	179	203	229	267
C	Flange diameter ANSI RF	mm	152	191	229	279
D	Total flange thickness ANSI RF	mm	15.9	19.1	23.8	25.4
E	CL to top of stem	mm	152	210	230	292
F	CL to bottom of body	mm	103	137	151	209
H	Maximum width	mm	135	186	198	289
J	Size of plug square	mm	27.0	38.1	41.3	50.8
K	Depth of plug square	mm	28.6	30.2	44.5	54.0
O	Raised face diameter ANSI RF	mm	92.1	127	157	216
P	Clearance to remove screw or lubricator	mm	225	297	327	414
	Jacket connection size screwed API	in	3/4"	3/4"	3/4"	3/4"
	Number of connections		3	3	3	3
	Positions of connections		1R 1L	1R 1L	1R 1L	1R 1L
			9	9	9	9
Q4	Maximum width between connections	mm	135	186	198	289
	Weight (approx)	kg	16	31	42	114
	Wrench number		4H	6H	7H	10H
	Sealant stick size		B	C	D	E

Valves are normally supplied with drilled Class 150 flanges having serrated finish raised faces in accordance with ANSI B16.5. Most valves on this page can be supplied with flange drillings to BS EN1092-1 PN16.

Maximum pressure in jacket 150 lbf/in².

Class 300 valves in size range 25mm to 100mm are available on request.

Jacketed Valves With Oversize Flanges

MZL233CC 25-100mm

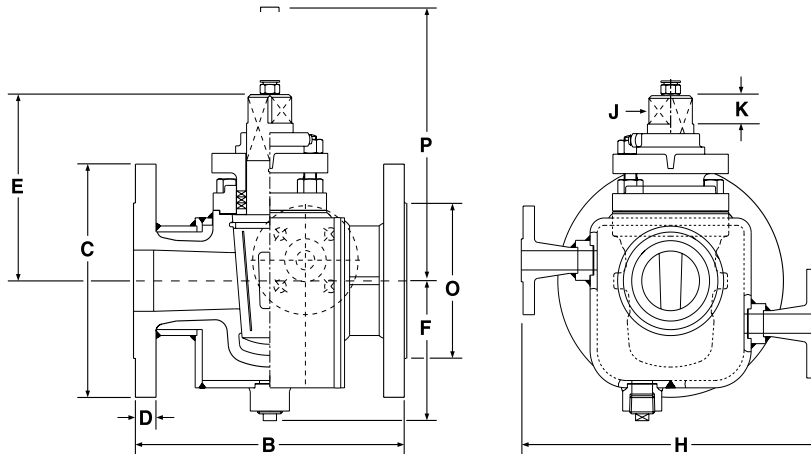

Valves have face-to-face dimensions conforming to BS 5158 PN 10/16, BS 2080 Class 150 Short, ANSI B16.10 & API 6D Class 150 Short. These valves are thus interchangeable with equivalent gate valves. Valves have Patterns conforming to BS 5353, BS 5158, API 6D & API 599 Short (with steel plug).

Valves have face-to-face dimensions confirming to BS EN 558 Basic Series-1.

			50x25x50	80x50x80	100x80x100	150x100x150
B	Face-to-face flanged RF	mm	160	230	310	350
C	Flange diameter ANSI RF	mm	152	191	229	280
D	Total flange thickness ANSI RF	mm	15.8	19	24	25.4
E	CL to top of stem	mm	118	152	207	230
F	CL to bottom of body	mm	-	-	-	-
H	Maximum width	mm	-	-	-	-
J	Size of plug square	mm	22	27	38	41
K	Depth of plug square	mm	21	28	30	44
O	Raised face diameter ANSI RF	mm	92	127	157	216
P	Clearance to remove screw or lubricator	mm	-	-	-	-
	Jacket connection size screwed API	in	-	-	-	-
	Number of connections		3	3	3	3
	Positions of connections		1R 1L	1R 1L	1R 1L	1R 1L

Valves are normally supplied with drilled Class 150 flanges having serrated finish raised faces in accordance with ANSI B16.5. Maximum pressure in jacket 150 lbf/in².

Jacketed Valves With Oversize Flanges

MZG233CC 100-300mm

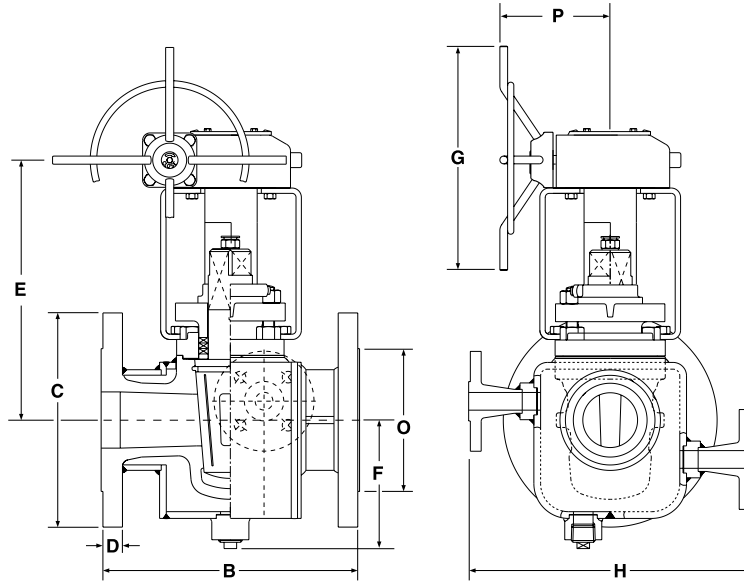

Valves have face-to-face dimensions conforming to BS EN 558 Basic Series-1.

			150x100x150	200x150x200	250x200x250	300x250x300
B	Face-to-face flanged RF	mm	350	480	600	730
C	Flange diameter ANSI RF	mm	280	343	407	483
D	Total flange thickness ANSI RF	mm	25.4	28.4	30.2	31.8
E	CL to gearbox CL	mm	354	315	330	375
F	CL to bottom of body	mm	-	-	-	-
G	Handwheel diameter	mm	578	578	578	578
H	Maximum width	mm	-	-	-	-
O	Raised face diameter ANSI RF	mm	216	270	324	381
P	CL to handwheel	mm	307	307	307	307
	Jacket connection size screwed API	in				
	Number of connections		3	3	3	3
	Positions of connections		1R 1L	1R 1L	1R 1L	1R 1L

Valves are normally supplied with drilled Class 150 flanges having serrated finish raised faces in accordance with BS 1560 & ANSI B16.5.

Maximum pressure in jacket 150 lbf/in².



Flowserve India Controls Pvt Ltd
B-8, CMDA Industrial Area,
Maraimalai Nagar - 603 209,
Kanchipuram Dist, Tamil Nadu, India.
(T) +91-44-27452323
(F) +91-44-27452327
Email : Audcoplugindia@flowserve.com

FCD AUUEBT0003-01 06/13.

To find your local Flowserve representative
or for more information about Flowserve Corporation,
visit www.flowserve.com

Flowserve Corporation has established industry leadership in the design and manufacture of its products. When properly selected, this Flowserve product is designed to perform its intended function safely during its useful life. However, the purchaser or user of Flowserve products should be aware that Flowserve products might be used in numerous applications under a wide variety of industrial service conditions. Although Flowserve can (and often does) provide general guidelines, it cannot provide specific data and warnings for all possible applications. The purchaser/user must therefore assume the ultimate responsibility for the proper sizing and selection, installation, operation, and maintenance of Flowserve products. The purchaser/user should read and understand the Installation Operation Maintenance (IOM) instructions included with the product, and train its employees and contractors in the safe use of Flowserve products in connection with the specific application.

While the information and specifications contained in this literature are believed to be accurate, they are supplied for informative purposes only and should not be considered certified or as a guarantee of satisfactory results by reliance thereon. Nothing contained herein is to be construed as a warranty or guarantee, express or implied, regarding any matter with respect to this product. Because Flowserve is continually improving and upgrading its product design, the specifications, dimensions and information contained herein are subject to change without notice. Should any question arise concerning these provisions, the purchaser/user should contact Flowserve Corporation at any one of its worldwide operations or offices.

© 2013 Flowserve Corporation, Irving, Texas, USA. Flowserve is a registered trademark of Flowserve Corporation.